

MINOLTA

**UC 6**

# **Installation Instructions\***

**For Minolta**

**MicroSP2000 / MS2000 Scanner**

\* This unit should be installed by a Qualified Technician

**Start with a fully functional host machine before installation.**

**Restore host machine functions if necessary.**

**Unplug host machine from wall outlet before  
attempting this installation.**

# Minolta MS2000 Scanner

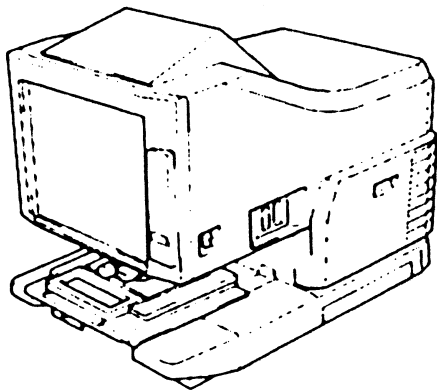

MS2000

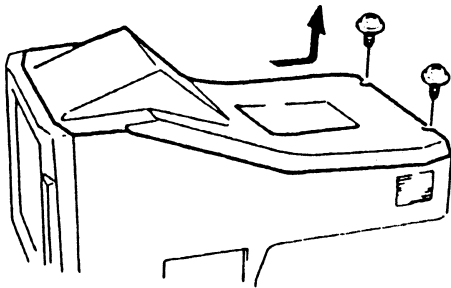

**A.** Remove the Optical Cover.  
(2 Screws)

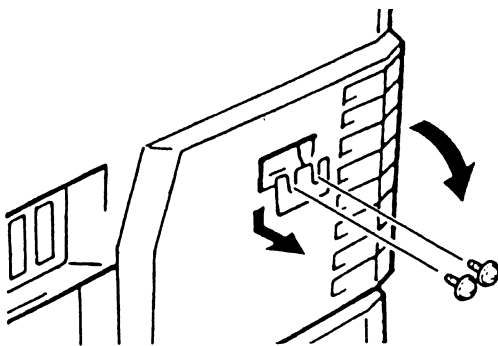

**B.** Remove the stopper from the Right Cover and then open the Right Cover (2 screws).

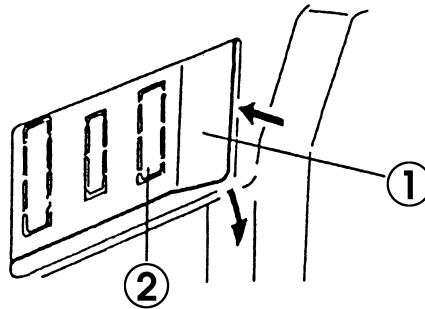

**C.** Remove the Interface Cover (1). Then cut out the connector Cover (2) from the Interface Cover.

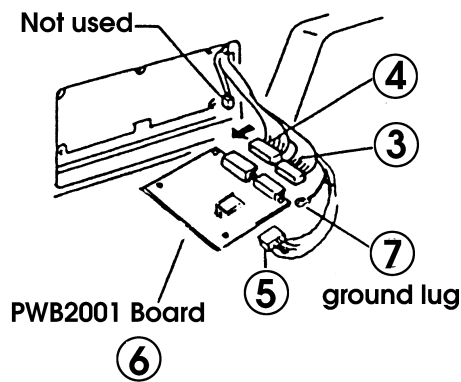

**D.** Connect the Reader Printer 5P-connector (4) to the PWB2001 Board (6).

Connect the small 6P-connector (5) and the large 6P-connector (3) from Interconnect Cable Assembly to the PWB2001 Board.

**NOTE:** Install ground plug (7) from the Interconnect Cable Assembly between the board and the metal mounting plate in the upper right hand corner.

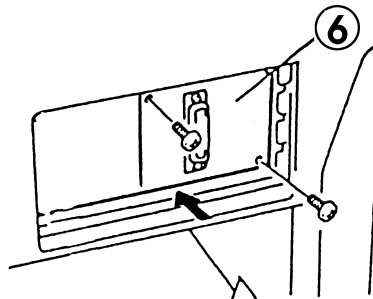

**E.** Install the PWB2001 Board (6) to the machine by using the 3 screws provided.

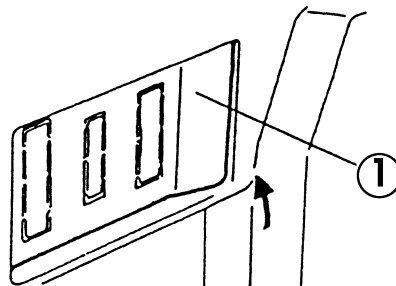

**F.** Replace the Interface Cover (1).

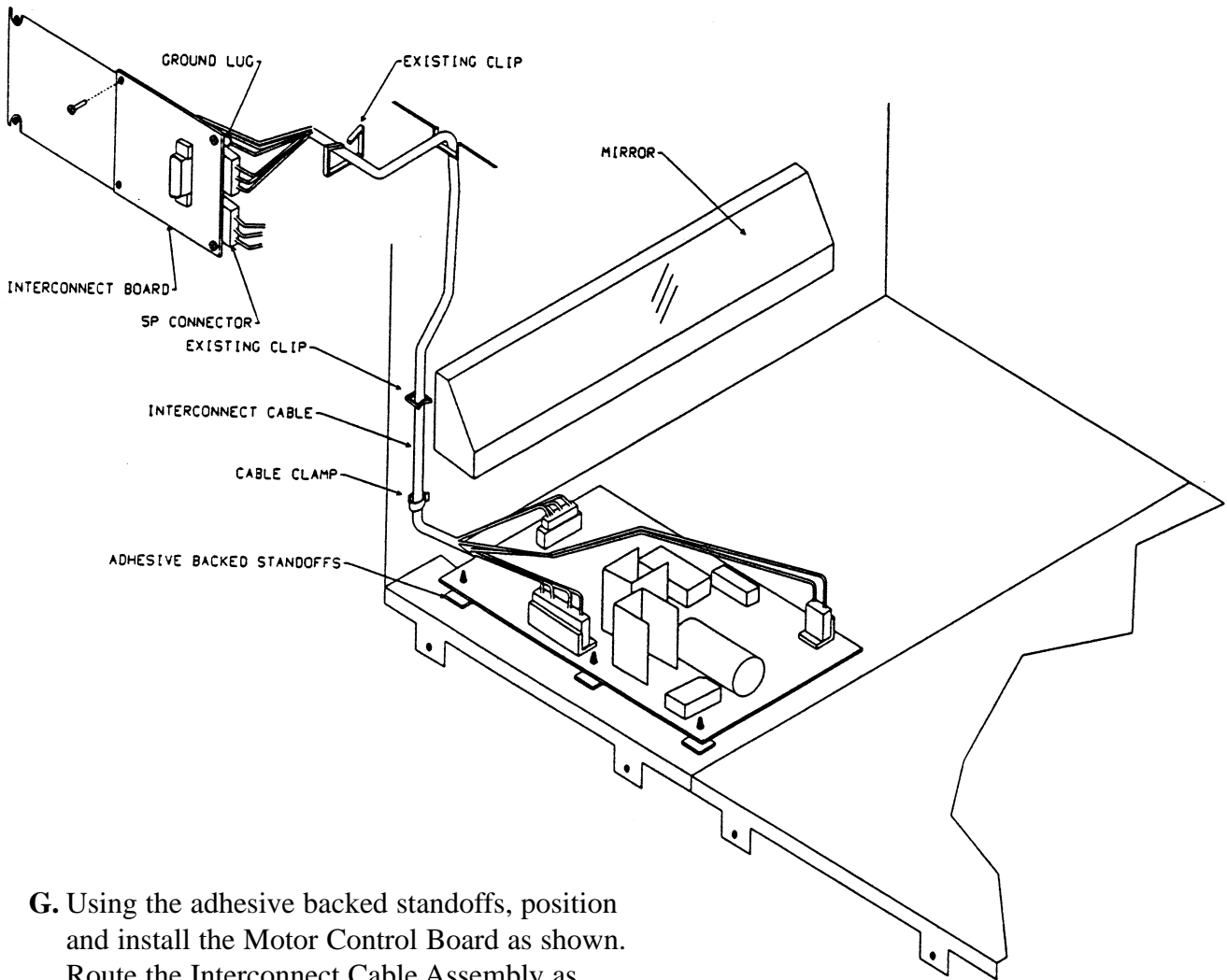

**G.** Using the adhesive backed standoffs, position and install the Motor Control Board as shown. Route the Interconnect Cable Assembly as shown, using existing cable wiring clips. Add cable clamps and wire ties as necessary.

**NOTE: Route wires away from sharp metal edges and away from moving parts.**

**H.** Install the UC 6 Carrier and connect the 15Pin D-connector to the PWB2001 Board. Apply power to the Reader Printer, and check the carrier installation for proper function.

**I. If Okay...**Install the Right Cover and the Optical Cover.