

MINOLTA

UC 6

Installation Instructions*

For

Minolta

RP605Z / RP606Z

* This unit should be installed by a Qualified Technician

Start with a fully functional host machine before installation.

Restore host machine functions if necessary.

**Unplug host machine from wall outlet before
attempting this installation.**

RP605Z / RP606Z

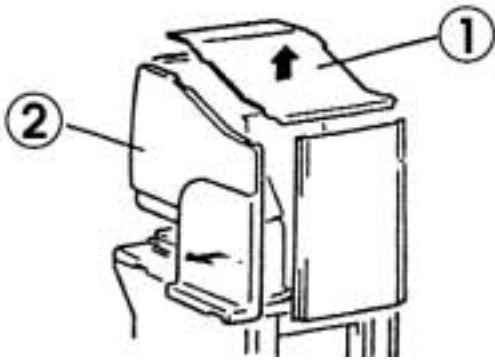

1. Remove the following Covers:
 - Top Cover (1)
 - Upper right Side Cover (2)

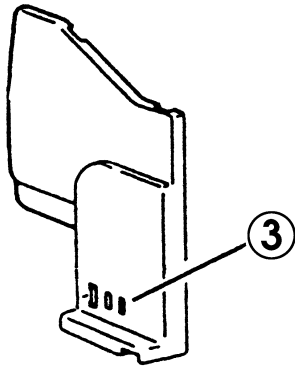

2. Cut out the connector Cover (3) from the Interface Cover.

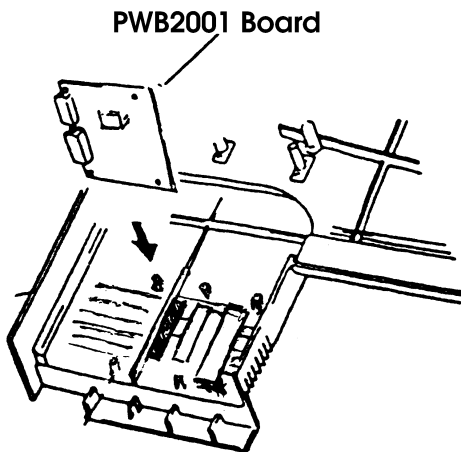

3. Install the PWB2001 Board to the machine by using the four screws provided.

4. Connect the leads from Interconnect Cable Assembly to the PWB2001 board, connect Reader Printer 5P-connector (4) to the PWB2001 Board.

Connect the small 6P-connector (5) and large 6P-connector (3) from the Interconnect Cable Assembly to the PWB2001 Board

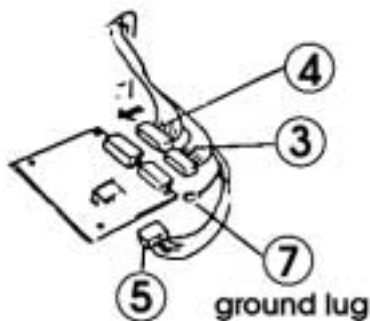

NOTE:

Install ground lug (7) from the Interconnect Cable Assembly between the screw head and the upper right hole of the board, foil side.

5. Remove wire hold down from hole (B) and relocate to hole (E), see figure 6 below. Using existing holes (A) and (B) to mount the Motor Control Board with the nylon spacers provided.

Figure 6

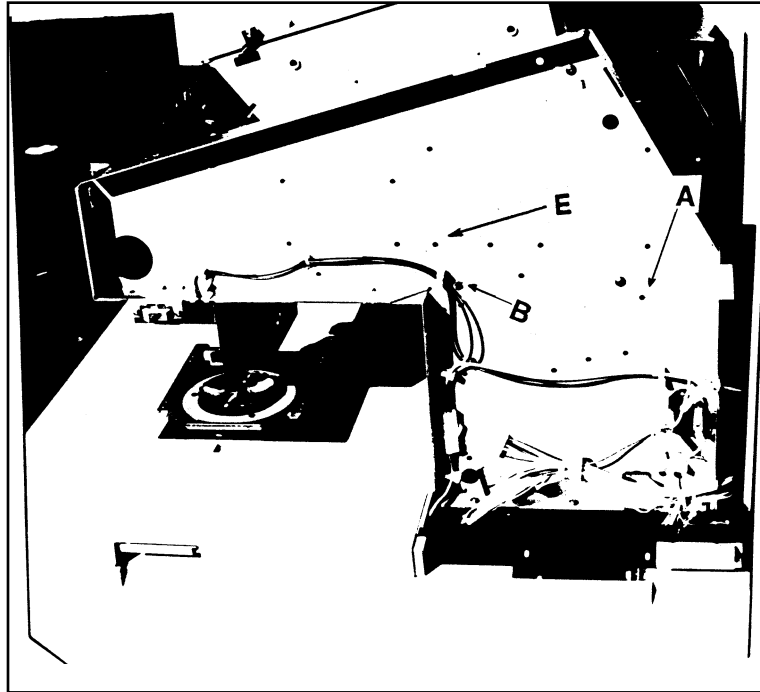

6. See diagram on next page for routing of Interconnect Cable Assembly, add cable clamps and wire ties as necessary.
7. Mount UC 6 Carrier on Reader Printer and plug the 15Pin D-connector to the PWB2001 Board. Apply power to the Reader Printer and check the UC 6 Carrier for proper functions.
8. Re-install Covers on unit and installation is complete.

