

MINOLTA

UC 6

Installation Instructions*

**For
Minolta RP603Z**

* This unit should be installed by a Qualified Technician

Start with a fully functional host machine before installation.

Restore host machine functions if necessary.

**Unplug host machine from wall outlet before
attempting this installation.**

Minolta RP603Z

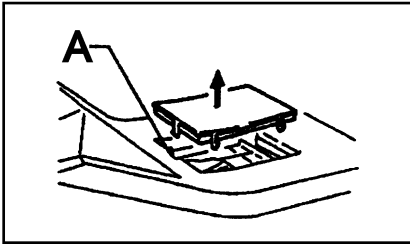

1. Removal of Outer Covers

Insert the head of the Slotted driver into (A) part in the illustration and remove the Top Cover.

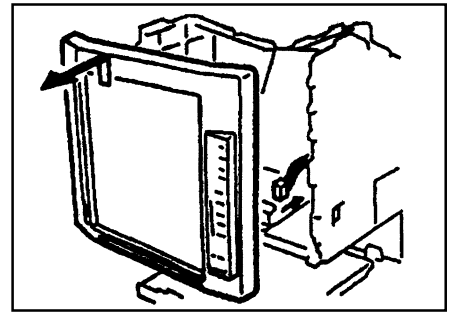

4. Remove the Screen frame.

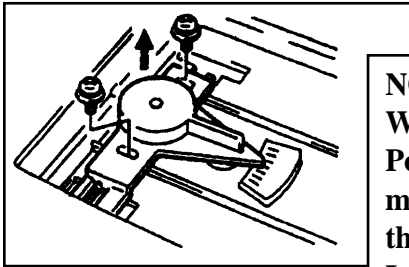

2. Remove two screws and then remove the Mirror Positioning Lever.

NOTE:

When installing the Mirror Positioning Lever into the machine, align the pointer of the Mirror Positioning Lever with the same position as that (▲) indicated on the back of the Top Cover. Then, screw it into position.

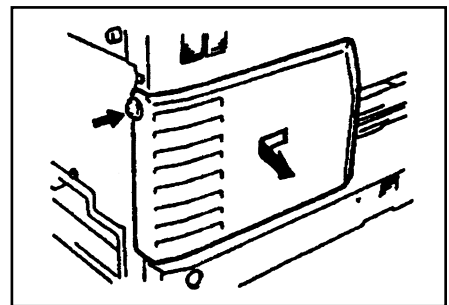

5. Remove the Left Cover.

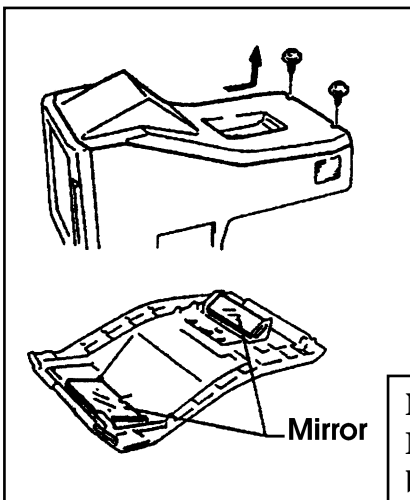

3. Remove two screws and then slide the Optical Cover back to the rear side of the machine.

Then holding up the rear side of the Cover, remove the Optical Cover.

NOTE:

Mirrors are fitted to the back side of the Optical Cover. Using care not to touch or damage these mirrors, place the Optical Cover upside down.

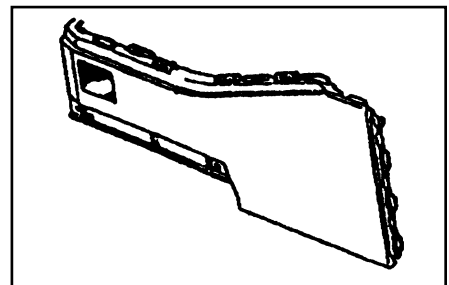

6. Remove the Left Frame Cover.

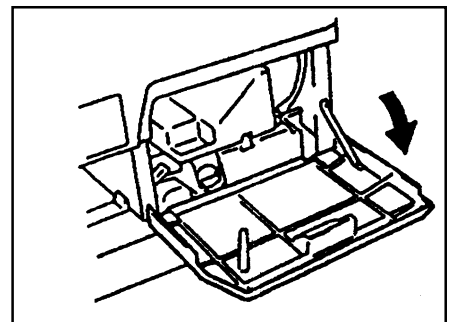

7. Open Right Cover.

- Drill holes for mounting the control board on the left side metal panel.
Use the template on page 11 to drill two 3/16" diam. holes.
See photo (A) on page 8 for more details.

Follow diagram below for mounting the Control Board and for routing cable.

NOTE:
Route wires away from sharp edges and away from moving parts.

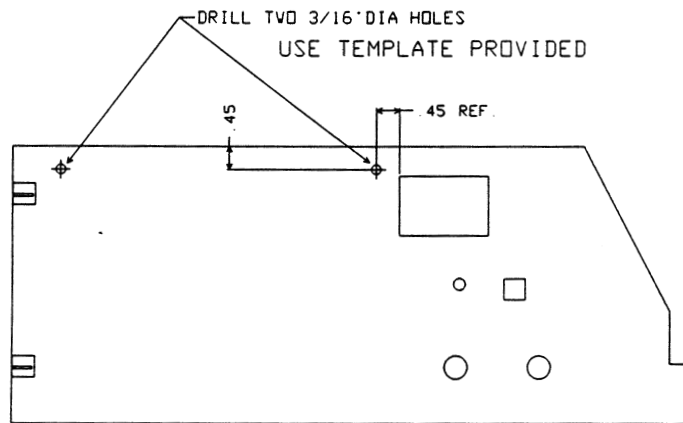
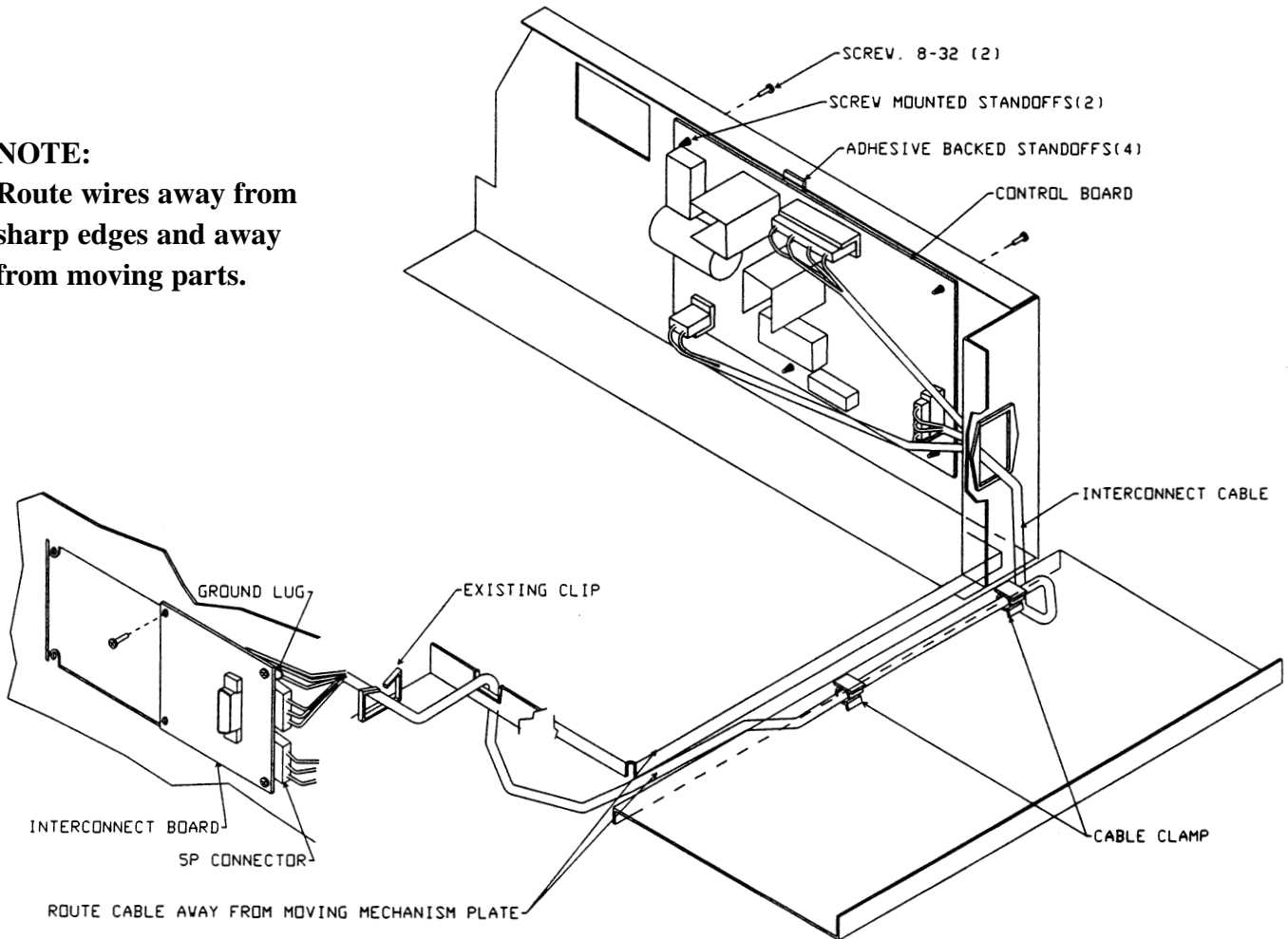

See Template on page 11.

NOTE:
When routing cable under frame, position clamps to have clearance when the Upper Unit is raised.

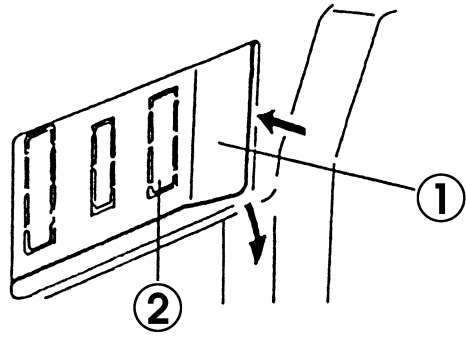

9. Remove the Interface Cover (1). Then cut out the connector Cover (2) from the Interface Cover.

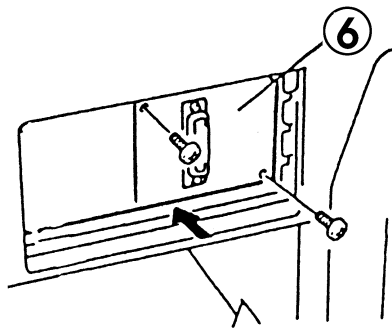

11. Install the PWB2001 Board to the machine by using 3 screws provided.

NOTE:
Install ground lug (7) from the Interconnect Cable Assembly between the board and the metal mounting plate in the upper right hole.

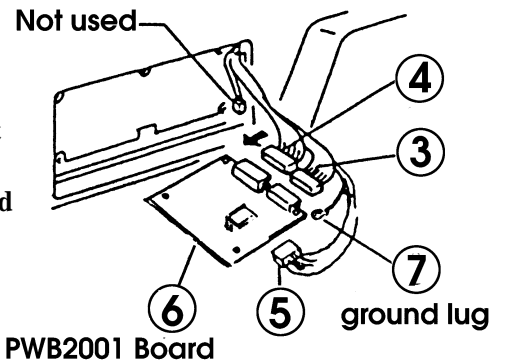

10. After routing cable, connect the Reader Printer 5P-connector (4) to the PWB Board (6). Connect the small 6P-connector (5) and the large 6P-connector (3) from the Interconnect Cable Assembly to the PWB2001 Board.

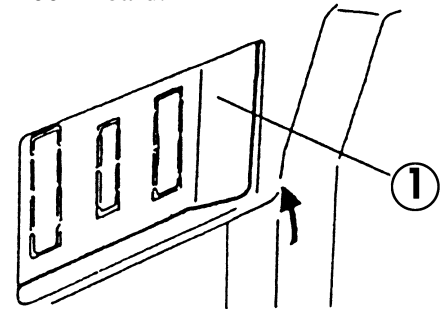

12. Replace the Interface Cover (1).

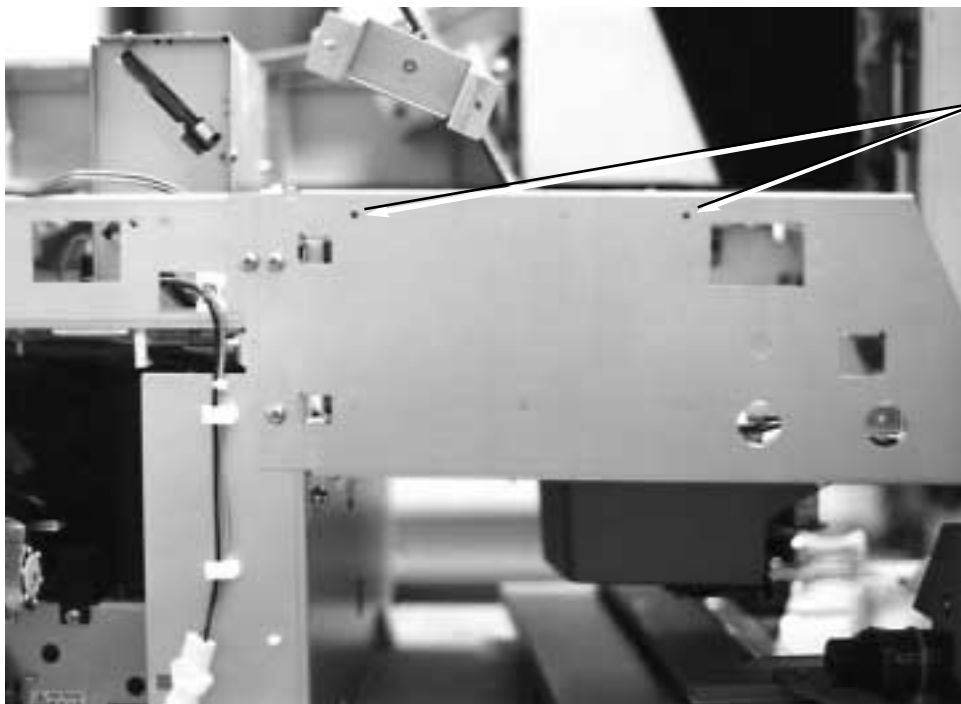

A. Left Side Metal Frame

Drill two 3/16" dia. holes. (Use Template on page 11)

NOTE:

When drilling holes to mount the Control Board, make sure to place a cloth or sheet of paper to collect any metal filings on the inside of the unit!

Completion of Installation

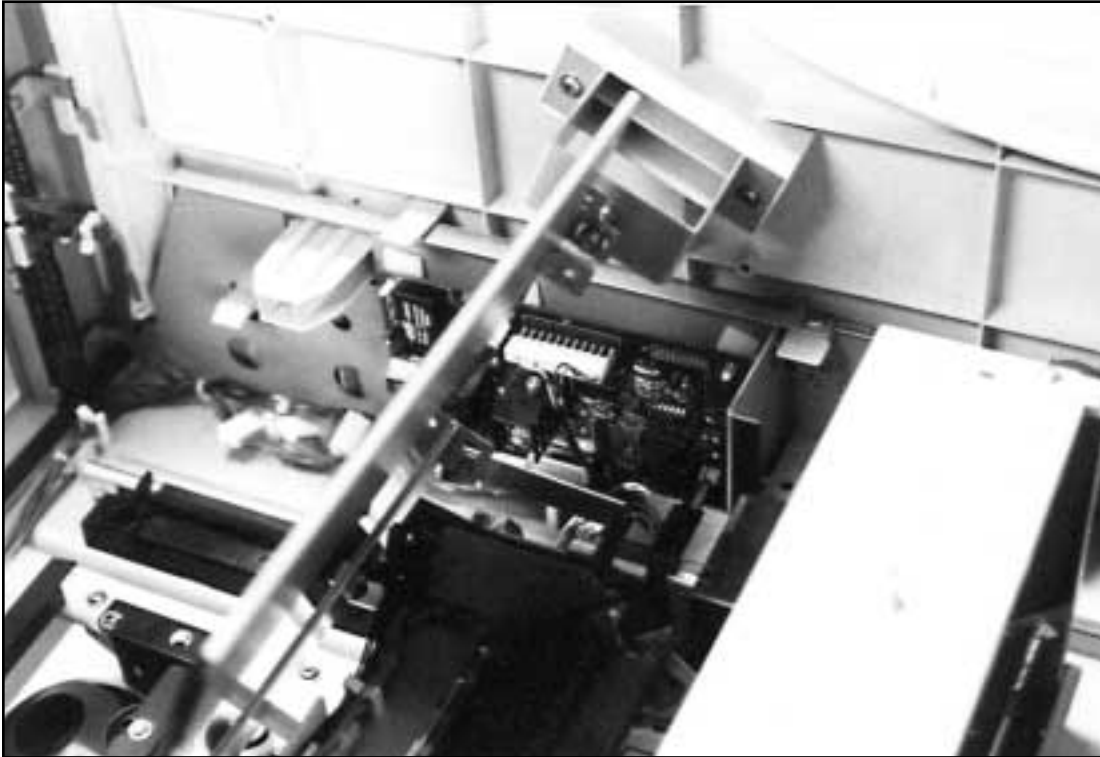

13. After installing Control Board with two screws and four adhesive back stand offs, reinstall Left Side Cover (see picture).

Mount Universal Carrier on Reader Printer, connect the 15 Pin-connector to the PWB2001 board. Apply power to Reader Printer, and check the carrier installation for proper function.

If OK, install all covers on machine.

ALIGN WITH EDGE OF RECTANGULAR HOLE →

ALIGN WITH TOP OF PANEL →

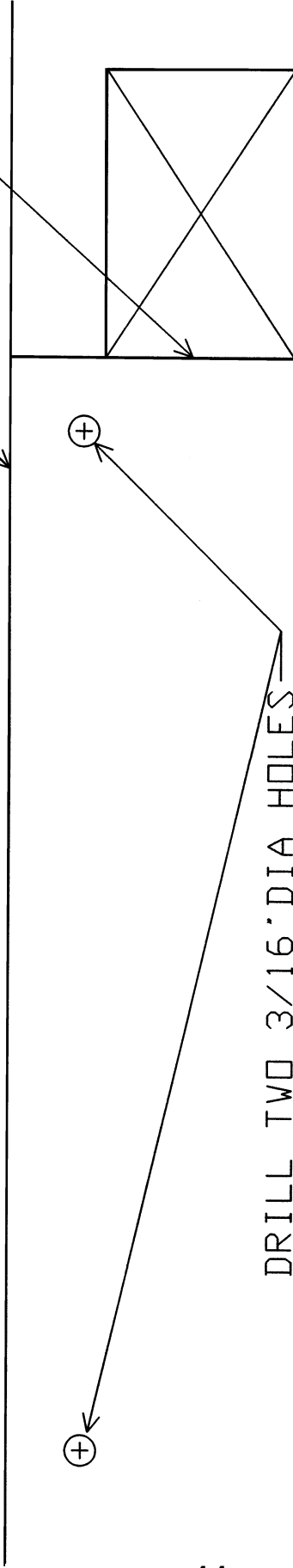

DRILL TWO 3/16" DIA HOLES →

TEMPLATE
LEFT SIDE METAL PANEL
MINOLTA RP603Z