

## Step 2

### INSTALLING THE POWER JACK - continued

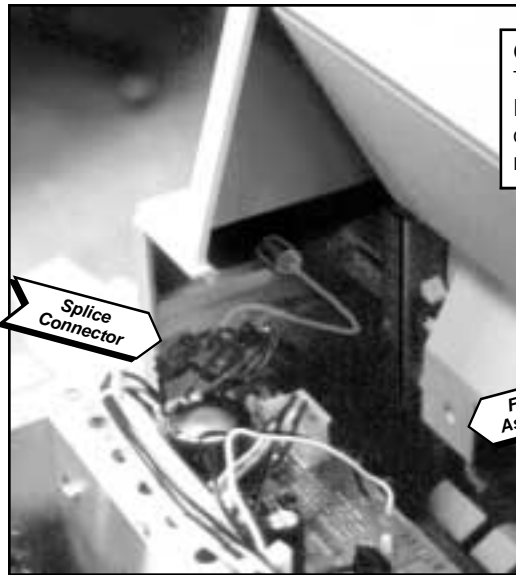

**CAUTION -**  
Take care to route the Power Jack wires so they do not interfere with movement of feeder assembly.

**D. Routing the Power Jack wires .**  
Check Power Jack for 24VDC.

**E. Reinstall all covers and mount Combo Carrier.**

#### PARTS OF THE READER/PRINTER & DC POWER JACK LOCATION

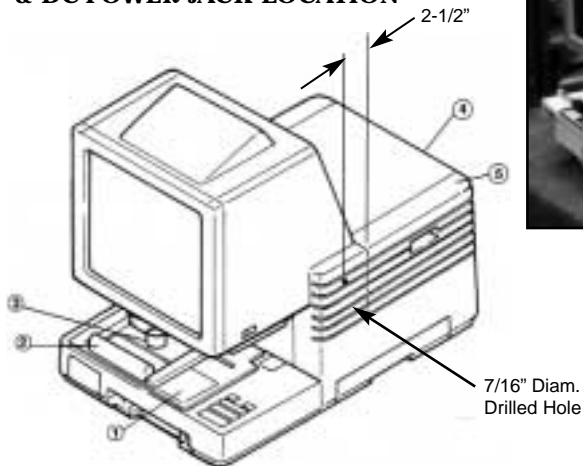

1. Carrier Stage
2. Fiche Carrier
3. Lens Holder
4. Rear Top Cover
5. Open/Close Cover

# EYECOM PrintMaster 10,000

# CANON MP60

## INSTALLATION INSTRUCTIONS

### For COMBO MOTORIZED CARRIER

THIS UNIT SHOULD BE INSTALLED BY A QUALIFIED TECHNICIAN

For any questions regarding installation,  
please call S-T Imaging, Inc. at 847 / 437-9900



S-T IMAGING, INC.

*a subsidiary of Digital Check Corp.*

466 Central Avenue, Suite 31 • Northfield, IL 60093

Phone: (847) 501-3344 • Fax: (847) 501-3377

web site: [www.stimaging.com](http://www.stimaging.com)

e-mail: [info@stimaging.com](mailto:info@stimaging.com)

## Step 1

### REMOVING THE REAR TOP COVER

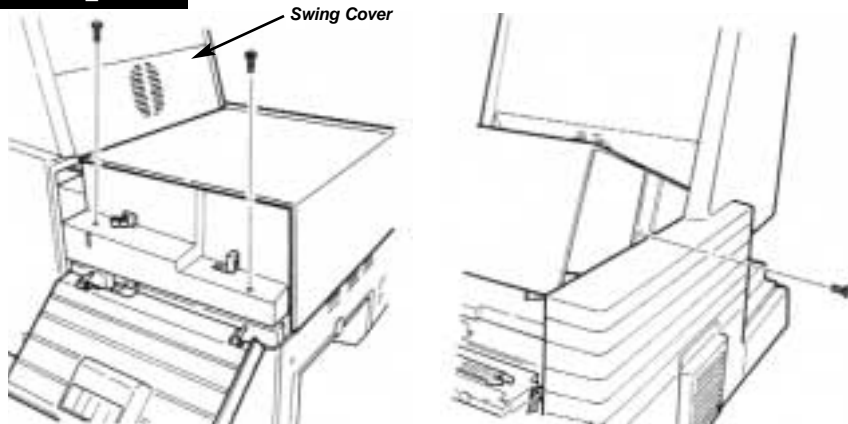

- A. Open the “open/close” cover and open the feeder assembly. Remove the three screws as shown.

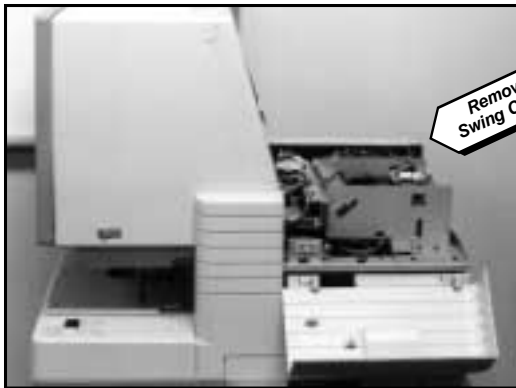

- B. Close the feeder assembly.

Lift up the swing cover by pushing up the rear of the rear top cover by a few centimeters and disconnect the swing cover from the rear top cover.



- C. Lower the rear of the rear top cover to just before a point where the feeder assembly closes, and remove the cover by shifting it backwards.

## Step 2

### INSTALLING THE POWER JACK

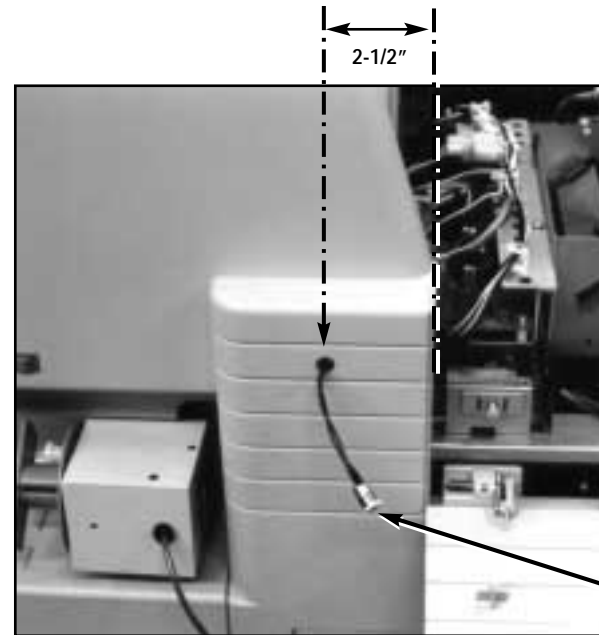

- A. Drill a 7/16” hole in the location shown at left.

**CAUTION** - Take care to prevent the drilling chips from falling into the unit.

- B. Install the Power Jack with the hardware provided.

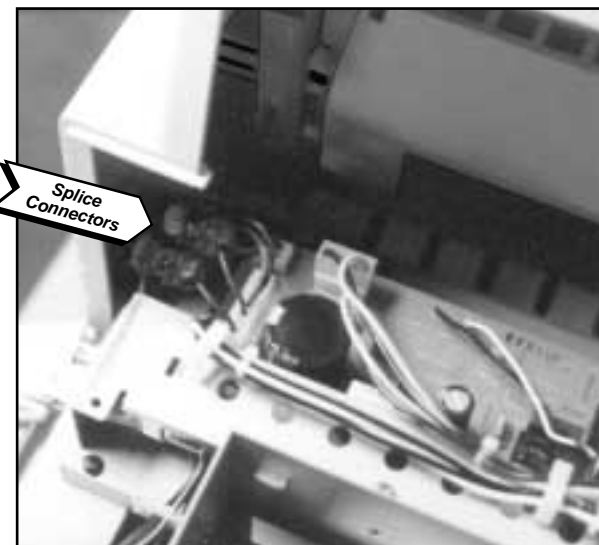

- C. Use the Splice Connectors that are provided to connect the RED WIRES and BLUE WIRES together the J406 PIN 1 and 2 respectively, on the DC power supply board.